

**UNIVERSITY COLLEGE TATI (UC TATI)****FINAL EXAMINATION QUESTION BOOKLET**

COURSE CODE	: BMT 2122
COURSE	: DYNAMIC & MECHANISM
SEMESTER/SESSION	: 2-2023/2024
DURATION	: 2 HOURS

**Instructions:**

1. This booklet contains 4 questions. Answer **ALL** questions.
2. All answers should be written in answer booklet.
3. Write legibly and draw sketches wherever required.
4. If in doubt, raise your hands and ask the invigilator.

**DO NOT OPEN THIS BOOKLET UNTIL YOU ARE TOLD TO DO SO**

**THIS BOOKLET CONTAINS 6 PRINTED PAGES INCLUDING COVER PAGE**

**QUESTION 1**

- a) The motion of a particle is defined by the relation  $x = 6t^4 - 2t^3 - 12t^2 + 3t + 3$ , where  $x$  and  $t$  are expressed in meters and seconds, respectively. Find the position, the velocity, when  $a = 0$ . (5 marks)

- b) A truck travels 220 m in 10 s while being decelerated at a constant rate of  $0.6 \text{ m/s}^2$ .

**Compute**

- i. Its initial velocity (3 marks)
  - ii. its final velocity (3 marks)
  - iii. The distance traveled during the first 1.5 s (4 marks)
- c) A ball is thrown from A. If it is required to clear the wall at B, **determine** the minimum magnitude of its initial velocity  $V_A$  in Figure 1. (10 marks)

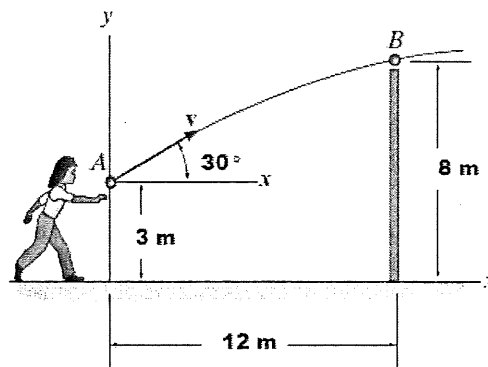

Figure 1

**QUESTION 2**

- a) A 80-kg block rests on a horizontal plane shown in Figure 2. Find the magnitude of the force  $P$  required to give the block an acceleration of  $2.5 \text{ m/s}^2$  to the right. The coefficient of kinetic friction between the block and plane is  $\mu_k = 0.25$ . (5 marks)

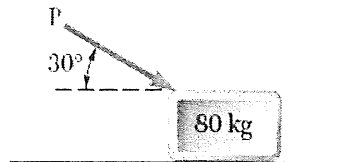

Figure 2

- b) If the motor exerts a constant force of 300 N on the cable shown in Figure 3, solve the speed of the 20-kg crate when it travels up the plane, starting from rest. The coefficient of kinetic friction between the crate and the plane is  $\mu_k = 0.3$ . (10 marks)

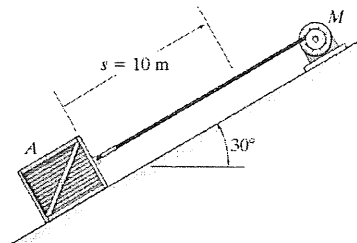

Figure 3

- c) Blocks A and B shown in Figure 4 have a mass of 3 kg and 5 kg, respectively. If the system is released from rest, determine the velocity of block B in 6 s. Neglect the mass of the pulleys and cord. (10 marks)

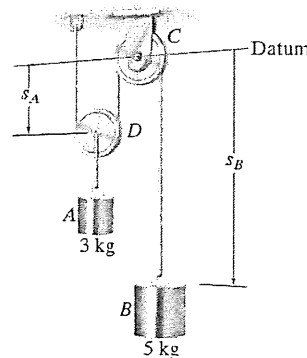

Figure 4

## QUESTION 3

- a) A particle travels along a straight line with a speed  $v = (4t - 3t^2)$  m/s, where  $t$  is in seconds. **Compute** the position of the particle when  $t = 4$  s (5 marks)
- b) The angular acceleration of the disk is defined by  $\alpha = 3t^2 + 12$  rad/s, where  $t$  is in seconds. If the disk is originally rotating at  $\omega_0 = 12$  rad/s in Figure 5, **solve**
- the velocity (3 marks)
  - the normal,  $n$  and tangential,  $t$  components of acceleration of point A on the disk when  $t = 2$  s (7 marks)

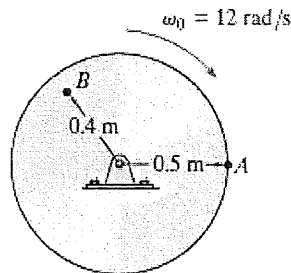

Figure 5

- c) If roller A moves to the right with a constant velocity of  $v_A = 3$  m/s, **determine** the angular velocity of the link and the velocity of roller B at the instant  $\theta = 30^\circ$  shown in Figure 6. (10 marks)

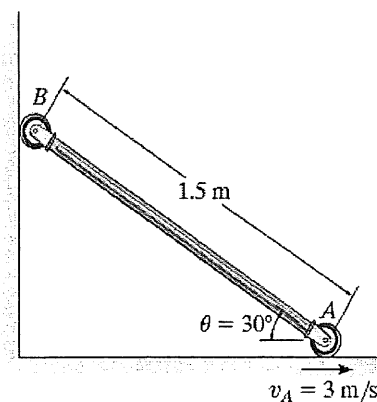

Figure 6

**QUESTION 4**

- a) A uniform 50 kg crate rests on a horizontal surface for which the coefficient of kinetic friction is  $\mu_k = 0.2$ . **Determine** the acceleration if a force of  $P = 600$  N is applied to the crate as shown in Figure 7. (10 marks)

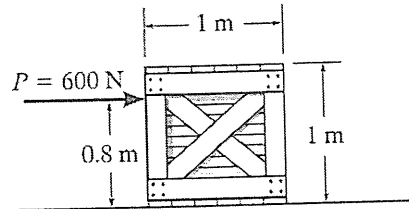

Figure 7

- b) The wheel has a radius of gyration about its mass center of O of  $k_o = 400$  mm shown in Figure 8. **Determine** its angular velocity after it has rotated 20 revolutions starting from rest. (15 marks)

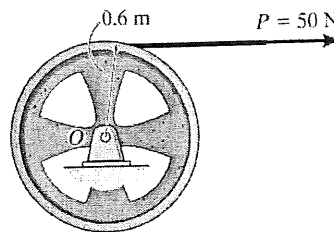

Figure 8

-----End of question-----

DYNAMIC & MECHANISM (BMT 2122)

FORMULA

Newton's 2<sup>nd</sup> Law:

$$\sum F = ma$$

Equation of Linear Motion:

$$v = v_0 + a_c t$$

$$s = s_0 + v_0 t + \frac{1}{2} a_c t^2$$

$$v^2 = v_0^2 + 2a_c (s - s_0)$$

Kinetics of Particle:

Newton's Second Law:

$$\sum F_x = ma_x$$

$$\sum F_y = ma_y$$

Principle of Work and Energy:

$$\sum T_1 + \sum U_{1-2} = \sum T_2$$

Work of Friction Caused by Sliding.

$$\frac{1}{2}mv^2 + Ps - \mu_k Ns = \frac{1}{2}mv^2$$

Principle of Impulse and Momentum:

$$mv_1 + \sum \int_{t_1}^{t_2} F dt = mv_2$$

Friction:

$$F = \mu_k N$$

Kinetics of Rigid Body:

Equations of Motion: Translation

$$\sum F_n = m(a_G)_n$$

$$\sum F_t = m(a_G)_t$$

$$\sum M_G = 0$$

Work and Energy

$$I_O = mk_O^2$$

$$T_2 = \frac{1}{2} I_O \omega^2$$

$$s = \theta r$$

Circular Motion:

$$\theta = rad$$

$$\omega = \frac{d\theta}{dt}, rad/s$$

$$\alpha = \frac{d\omega}{dt}, rad/s^2$$

Acceleration constant:

$$\omega = \omega_0 + \alpha_c t$$

$$\theta = \theta_0 + \omega_0 t + \frac{1}{2} \alpha_c t^2$$

$$\omega^2 = \omega_0^2 + 2\alpha_c (\theta - \theta_0)$$

Motion at Point P:

$$v = \omega r$$

$$a_t = \alpha r$$

$$a_n = \omega^2 r$$

Relative Motion Analysis: Velocity

$$v_B = v_A + v_{B/A}$$

$$v_B = v_A + \omega \times r_{B/A}$$

